

Local LCD Control Panel Repeater

Syncro View



Product Overview

- Designed and manufactured to the highest standards in a quality controlled environment the Syncro VIEW Marine fire alarm annunciator provides a simple and convenient method of extending the controls and indications of the Syncro ASM fire alarm control panel to other locations.
- The large, graphic liquid crystal display and high brightness LED indicators duplicate the indications on the Syncro ASM fire alarm control panel at up to 15 additional locations via a simple, two-wire serial data connection.
- The Syncro VIEW Marine is available in either a 24V DC powered option (which can be powered via an additional 2 cores from the Syncro ASM control panel, a maximum of 4 VIEW Marine Repeater Panels in this combination) or up to 15 VIEW Marine Repeater Panels if powered local from an ancillary 24V DC supply or a 230V powered option with local battery backup.
- Syncro VIEW Marine is housed in a small enclosure which is styled similarly to the Syncro ASM control panel and is ideal for installations where a large fire control panel would be detrimental to décor or where space is at a premium such as the Control Bridge or Helm.
- Up to 15 Syncro VIEW Marine annunciators can be connected to each control panel on the Syncro ASM network making VIEW Marine ideal where multiple points of indication and/or control are required in such as places as Engine Rooms, Staff Quarters, Living Spaces or Control Area's.

Features

- Up to 15 annunciators can be connected to each Syncro ASM fire control panel.
- Large liquid crystal display (240 x 64 pixels)
- High brightness LED indications
- Internal sounder
- Replicates all Syncro ASM panel controls
- Simple, two-wire serial connection
- Small, Syncro style enclosure
- Removable electronics for easy installation
- 24V DC or 230V AC power options
- Low power consumption
- Multi language options
- Connection monitored by Syncro ASM control panel

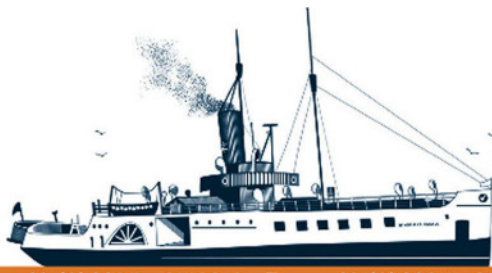

Addressable fire detection control panel

Syncro ASM

Technical Data

- Dimensions:
 - Recess mounting 310x241x42mm (MK)
 - Surface mounting 330x255x90mm
- Construction: -1.2mm Mild steel
- IP Rating: -IP30
- Cable entry: -5 x 20mm knockouts in top of box and 5 in rear
- Display: -8 lines of 40 characters graphic LCD
- Mains supply (Mains models only): -230V AC +10% - 15% (20 Watts maximum)
- 24V supply (24V DC models only): -21 to 30V DC
- Mains supply fuse: -2 Amp, 20mm
- Power supply rating: -28V 750mA total (including battery charging)
- Battery type (Yuasa NP): -Two 12 Volt 1.9Ah sealed lead acid in series
- Maximum current draw from batteries: -95mA
- Serial data connection: -2 core RS485 (Up to 1200 metres total cable length)
- Maximum terminal capacity: -2.5mm²

Connection

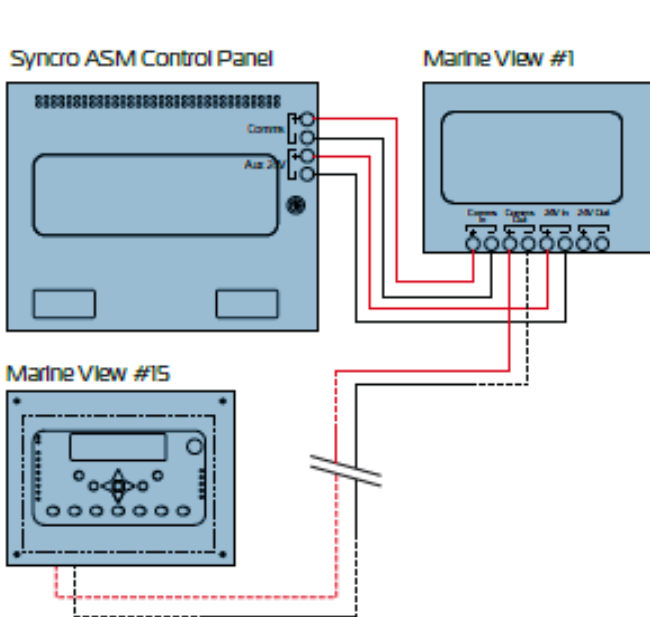

Dimensions

